

PARTS CATALOG

DADF-P1

Canon

Oct 12 2005

PREFACE

This Parts Catalog contains listings of parts used

Diagrams are provided with the listings to aid the service technician in identifying clearly, the item to be ordered.

Whenever ordering parts, consult this Parts Catalog for all of the information pertaining to each item. Be sure to include, in the Parts Request, the full item description, the item part number, and the quantity.

COPYRIGHT (C) 1999 CANON INC.

Use of this manual should be strictly supervised to avoid disclosure of confidential information.

Contents

NUMERICAL INDEX

DADF-P1	1-1
---------------	-----

DADF-P1

PA	ASSEMBLY LOCATION DIAGRAM	2-1
P01	PACKING KIT	2-2
P11	ADF ASSEMBLY	2-4
P12	DOCUMENT TRAY ASSEMBLY	2-7
P31	OPEN/CLOSE PANEL ASSEMBLY	2-9
P33	PAPER FEEDER ASSEMBLY	2-11

NUMERICAL INDEX

DADF-P1

PARTS NUMBER	FIGURE & KEY NO.	PARTS NUMBER	FIGURE & KEY NO.	PARTS NUMBER	FIGURE & KEY NO
FC3-1449-000	P11 - 10	FF3-4626-000	P12 - 6	FS2-9569-000	P31 - 20
FC3-1450-000	P11 - 11	FF3-4627-000	P12 - 8	FS2-9569-000	P33 - 33
FC3-1451-000	P11 - 23	FF3-4628-000	P12 - 9	FS2-9570-000	P11 - 36
FC3-1452-000	P11 - 12	FF3-4629-000	P31 - 1	FS2-9570-000	P33 - 31
FC3-1454-000	P11 - 13	FF3-4629-000	P31 - 8	FS2-9571-000	P11 - 50
FC3-1455-000	P11 - 14	FF3-4630-000	P31 - 9	FS2-9572-000	P12 - 15
FC3-1456-000	P01 - 1	FF3-4631-000	P33 - 19	FS2-9573-000	P31 - 19
FC3-1457-000	P01 - 2	FF3-4632-000	P33 - 20	FS4-0644-000	P33 - 34
FC3-1460-000	P33 - 1	FF3-4633-000	P33 - 16	FS4-0645-000	P33 - 23
FC3-1462-000	P33 - 2	FF3-4634-000	P11 - 8	FS4-0646-000	P33 - 35
FC3-1463-000	P33 - 3	FF3-4636-000	P33 - 17	FS4-0647-000	P33 - 36
FC3-1465-000	P33 - 4	FG3-4036-000	P12 -	FS4-0648-000	P33 - 37
FC3-1466-000	P33 - 5	FG3-4037-000	P31 -	FS4-0649-000	P33 - 38
FC3-1468-000	P11 - 1	FG3-4038-000	P33 -	FS4-0650-000	P33 - 39
FC3-1469-000	P33 - 6	FG3-4039-000	P11 - 22	FS4-0651-000	P33 - 40
FC3-1470-000	P33 - 7	FG3-4040-000	P33 - 18	FS4-0652-000	P33 - 41
FC3-1471-000	P33 - 8	FG3-4041-000	P31 - 14	FS4-0653-000	P33 - 42
FC3-1477-000	P31 - 2	FG3-4043-000	P31 - 10	FS4-0654-000	P31 - 21
FC3-1478-000	P31 - 3	FG3-4044-000	P31 - 15	FS4-0657-000	P12 - 16
FC3-1479-000	P31 - 4	FG3-4045-000	P31 - 16	FS4-0658-000	P12 - 17
FC3-1480-000	P31 - 5	FH2-7206-000	P11 - 32	FS4-0659-000	P33 - 43
FC3-1486-000	P12 - 2	FH2-7207-000	P12 - 10	FS4-0660-000	P33 - 44
FC3-1488-000	P12 - 3	FH2-7208-000	P12 - 11	FS4-2743-000	P11 - 31
FC3-1491-000	P11 - 15	FH2-7209-000	P33 - 25	FS4-2744-000	P33 - 45
FC3-1492-000	P11 - 2	FH2-7210-000	P11 - 33	FS4-2745-000	P33 - 46
FC3-1493-000	P33 - 9	FH2-7211-000	P11 - 25	FS4-2746-000	P33 - 21
FC3-1494-000	P33 - 10	FH2-7212-000	P12 - 12	FS4-2747-000	P31 - 22
FC3-1495-000	P11 - 16	FH5-1142-000	P33 - 49	FS4-2749-000	P33 - 52
FC3-1496-000	P11 - 3	FH5-3730-000	P11 - 34	FS4-2752-000	P33 - 24
FC3-1497-000	P11 - 17	FH5-3731-000	P12 - 13	FS4-2753-000	P33 - 47
FC3-1498-000	P11 - 18	FH6-5136-000	P11 - 16	FS4-2754-000	P31 - 1
FC3-1509-000	P33 - 11	FK2-0216-000	P11 - 20	FS9-0196-000	P01 - 6
FC3-1510-000	P33 - 12	FL2-2942-000	P01 - 10	FS9-0197-000	P11 - 21
FC3-1511-000	P33 - 13	FL2-3231-000	P01 - 12	FS9-0198-000	P11 - 6
FC3-1512-000	P33 - 14	FL2-3233-000	P01 - 13	FS9-0201-000	P11 - 37
FC3-1513-000	P11 - 24	FS2-1707-000	P11 - 27	FS9-0202-000	P11 - 37
FC3-1525-000	P31 - 11	FS2-1708-000	P31 - 17	FS9-0203-000	P11 - 9
FC3-1529-000	P12 - 5	FS2-1708-000	P33 - 26	FS9-0207-000	P11 - 38
FC3-1539-000	P11 - 4	FS2-1709-000	P33 - 27	FS9-0208-000	P11 - 38
FC3-1540-000	P31 - 6	FS2-1710-000	P31 - 18	FS9-0209-000	P11 - 38
FC3-1541-000	P31 - 7	FS2-1710-000	P33 - 28	FS9-0210-000	P12 - 7
FC3-1542-000	P31 - 12	FS2-1711-000	P33 - 29	FS9-0211-000	P01 - 7
FC3-1547-000	P01 - 3	FS2-3885-000	P33 - 22	FS9-0214-000	P01 - 8
FC3-1549-000	P11 - 19	FS2-3886-000	P33 - 30	FS9-0215-000	P01 - 11
FC3-1549-000	P31 - 13	FS2-3887-000	P33 - 31	NPN	P01 -
FC3-1549-000	P33 - 15	FS2-9540-000	P01 - 4	NPN	P11 -
FC3-1552-000	P11 - 39	FS2-9542-000	P01 - 5	WG8-5696-000	P12 - 1
FC3-1568-000	P33 - 53	FS2-9567-000	P11 - 35	WG8-5696-000	P33 - 48
FC6-4525-000	P01 - 9	FS2-9567-000	P33 - 32	XB1-1401-407	P11 - 503
FF3-4621-000	P11 - 5	FS2-9568-000	P11 - 28	XB2-4300-605	P11 - 501
FF3-4624-000	P11 - 7	FS2-9569-000	P11 - 29	XD2-1100-322	P33 - 501
FF3-4625-000	P12 - 4	FS2-9569-000	P12 - 14	XD2-1100-502	P31 - 501

NUMERICAL INDEX

DADF-P1

PARTS NUMBER	FIGURE & KEY NO.	PARTS NUMBER	FIGURE & KEY NO.	PARTS NUMBER	FIGURE & KEY NO.
XD2-1100-502	P33 - 503				
XD2-1100-642	P33 - 502				
XD3-2200-102	P11 - 502				
XD3-2200-102	P31 - 502				
XF2-1607-240	P33 - 50				

DADF-P1

DADF-P1

INCH/A	F26-7211-000	KRV
A	F26-7221-000	KRW
INCH/AB	F26-7231-000	KRX

Contents

PA	ASSEMBLY LOCATION DIAGRAM	2-1
P01	PACKING KIT	2-2
P11	ADF ASSEMBLY	2-4
P12	DOCUMENT TRAY ASSEMBLY	2-7
P31	OPEN/CLOSE PANEL ASSEMBLY	2-9
P33	PAPER FEEDER ASSEMBLY	2-11

FIGURE PA ASSEMBLY LOCATION DIAGRAM

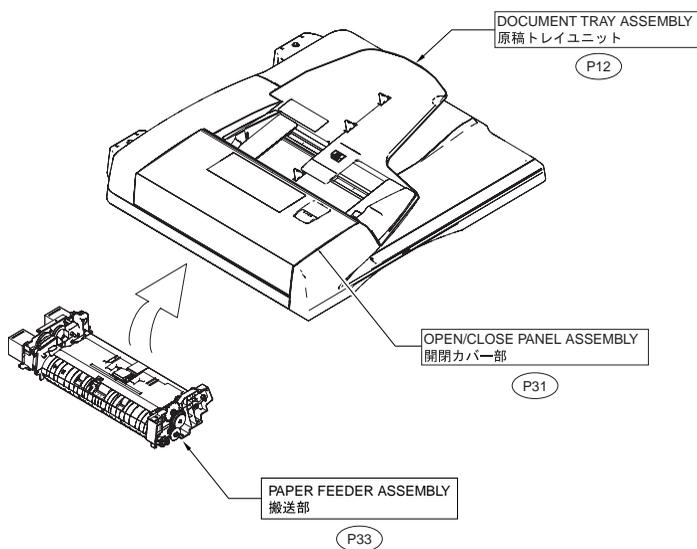

FIGURE P01 PACKING KIT

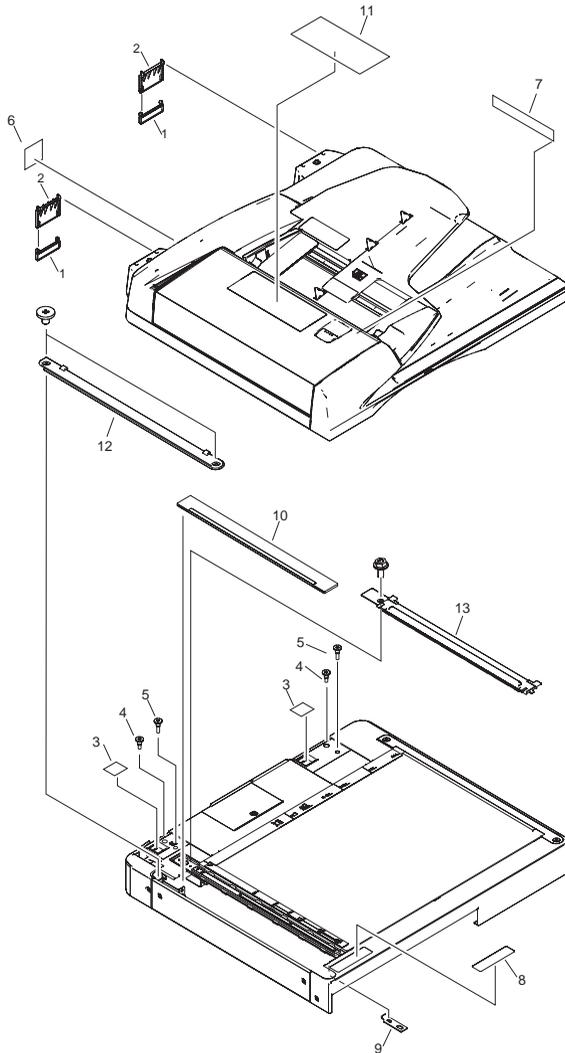

FIGURE & KEY NO.	PARTS NUMBER	R A N K	Q'TY	DESCRIPTION	SERIAL NUMBER/ REMARKS	S V C
Fig.P01	NPN		RF	PACKING KIT		
1	FC3-1456-000		2	COVER, HINGE		
2	FC3-1457-000		2	COVER, HINGE		
3	FC3-1547-000		2	SHEET, BLANKING		
4	FS2-9540-000		2	SCREW, STEPPED, M4		
5	FS2-9542-000		2	SCREW, STEPPED		
6	FS9-0196-000		1	LABEL, CAUTION		
7	FS9-0211-000		1	LABEL, DOCUMENT SIZE		
8	FS9-0214-000		1	LABEL, CLEANING		
9	FC6-4525-000		1	RETAINER, GLASS		
10	FL2-2942-000		1	GLASS, READER		
11	FS9-0215-000		1	LABEL		
12	FL2-3231-000		1	RETAINER, GLASS, LEFT		
13	FL2-3233-000		1	GUIDE, PAPER		

FIGURE P11 ADF ASSEMBLY

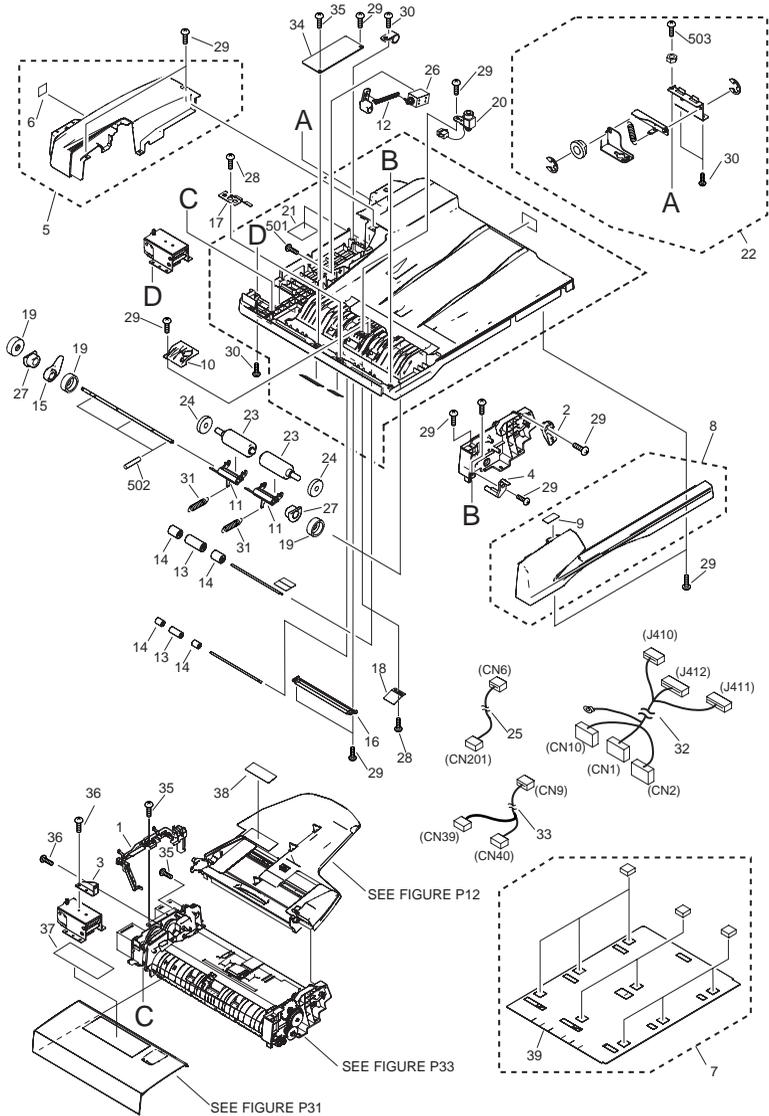

FIGURE & KEY NO.	PARTS NUMBER	R A N K	Q'TY	DESCRIPTION	SERIAL NUMBER/ REMARKS	S V C
Fig.P11	NPN		RF	ADF ASSEMBLY		
1	FC3-1468-000		1	HOLDER, HARNESS		
2	FC3-1492-000		1	HOLDER, TRAY SHAFT		
3	FC3-1496-000		1	BRACKET, SUPPORT		
4	FC3-1539-000		1	HOLDER, FEEDER SHAFT		
5	FF3-4621-000		1	PANEL, REAR		
6	FS9-0198-000		1	LABEL, HINGE CAUTION		
7	FF3-4624-000		1	PANEL, COPYBOARD		
8	FF3-4634-000		1	PANEL, FRONT		
9	FS9-0203-000		1	LABEL, DIAL OPERATION		
10	FC3-1449-000		1	COVER, STAMP		
11	FC3-1450-000		2	HOLDER, DELIVERY RELEASE		
12	FC3-1452-000		1	ARM, SOLENOID		
13	FC3-1454-000		2	ROLLER, PAPER FEED, 1		
14	FC3-1455-000		4	ROLLER, PAPER, FEED, 2		
15	FC3-1491-000		1	ARM, DELIVERY RELEASE		
16	FC3-1495-000		1	COVER, FEED		
17	FC3-1497-000		2	SPRING, LEAF		
18	FC3-1498-000		2	SPRING, LEAF		
19	FC3-1549-000		3	CLIP		
20	FK2-0216-000		1	SOLENOID		
21	FS9-0197-000		1	LABEL, HINGE CAUTION		
22	FG3-4039-000		1	HINGE UNIT(RIGHT)		
23	FC3-1451-000		2	ROLLER		
24	FC3-1513-000		2	ROLLER, PRESS		
25	FH2-7211-000		1	CABLE, STAMP		
26	FH6-5136-000		1	SOLENOID		
27	FS2-1707-000		2	BUSHING, DELIVERY RELEASE		
28	FS2-9568-000		4	SCREW, M3X8		
29	FS2-9569-000		12	SCREW, M3X10		
30	FS2-9571-000		7	SCREW, M4X12		
31	FS4-2743-000		2	SPRING		

FIGURE & KEY NO.	PARTS NUMBER	RANK	Q'TY	DESCRIPTION	SERIAL NUMBER/REMARKS	SVC
32	FH2-7206-000		1	CABLE, INTERFACE		
33	FH2-7210-000		1	CABLE, OPEN/CLOSE SENSOR		
34	FH5-3730-000		1	CONNECTION PCB UNIT		
35	FS2-9567-000		3	SCREW, M3X6		
36	FS2-9570-000		2	SCREW, M4X7		
37	FS9-0201-000		1	LABEL, DOCUMENT PROHIBITION	A INCH SIZE, AB INCH SIZE	
37	FS9-0202-000		1	LABEL, DOCUMENT PROHIBITION	A SIZE	
38	FS9-0207-000		1	LABEL, DOCUMENT SIZE	A INCH SIZE	
38	FS9-0208-000		1	LABEL, DOCUMENT SIZE	A SIZE	
38	FS9-0209-000		1	LABEL, DOCUMENT SIZE	AB INCH SIZE	
39	FC3-1552-000		1	COVER, COPYBOARD		
501	XB2-4300-605		1	SCREW, W/WASHER, M3X6		
502	XD3-2200-102		3	PIN, PARALLEL		
503	XB1-1401-407		1	SCREW, M4X14		

FIGURE P12 DOCUMENT TRAY ASSEMBLY

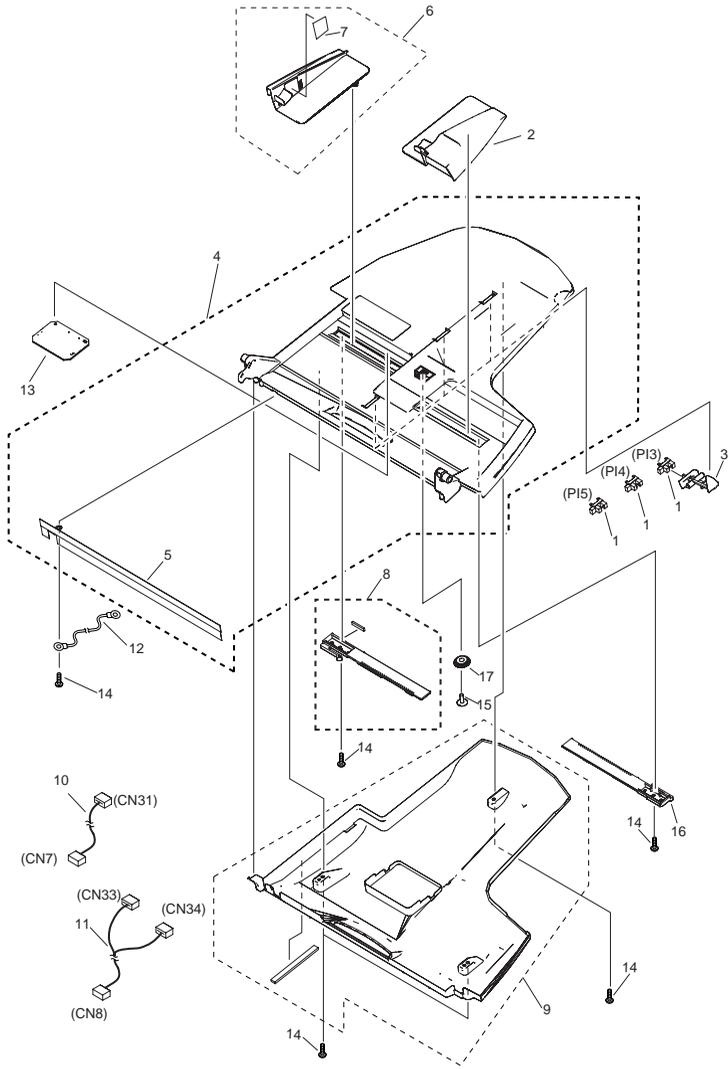

FIGURE & KEY NO.	PARTS NUMBER	R A N K	Q'TY	DESCRIPTION	SERIAL NUMBER/ REMARKS	S V C
Fig.P12	FG3-4036-000		1	DOCUMENT TRAY ASSEMBLY		
1	WG8-5696-000		3	PHOTO INTERRUPTER, TLP1243		
2	FC3-1486-000		1	GUIDE, TRAY, FRONT		
3	FC3-1488-000		3	LEVER, TRAY SENSOR		
4	FF3-4625-000		1	TRAY, DOCUMENT, UPPER		
5	FC3-1529-000		1	ELIMINATOR, STATIC CHARGE		
6	FF3-4626-000		1	GUIDE, TRAY		
7	FS9-0210-000		1	LABEL, DOCUMENT HEIGHT LIMIT		
8	FF3-4627-000		1	RACK, TRAY		
9	FF3-4628-000		1	COVER, TRAY, LOWER		
10	FH2-7207-000		1	CABLE, DOCUMENT TRAY	CN7,31	
11	FH2-7208-000		1	CABLE, SIZE DETECTION SENSOR	CN8,33,34	
12	FH2-7212-000		1	CABLE, STATIC ELIMINATOR		
13	FH5-3731-000		1	CONNECTING PCB UNIT		
14	FS2-9569-000		6	SCREW, M3X10		
15	FS2-9572-000		1	SCREW, M3X10		
16	FS4-0657-000		1	RACK, TRAY		
17	FS4-0658-000		1	GEAR, 16T		

FIGURE P31 OPEN/CLOSE PANEL ASSEMBLY

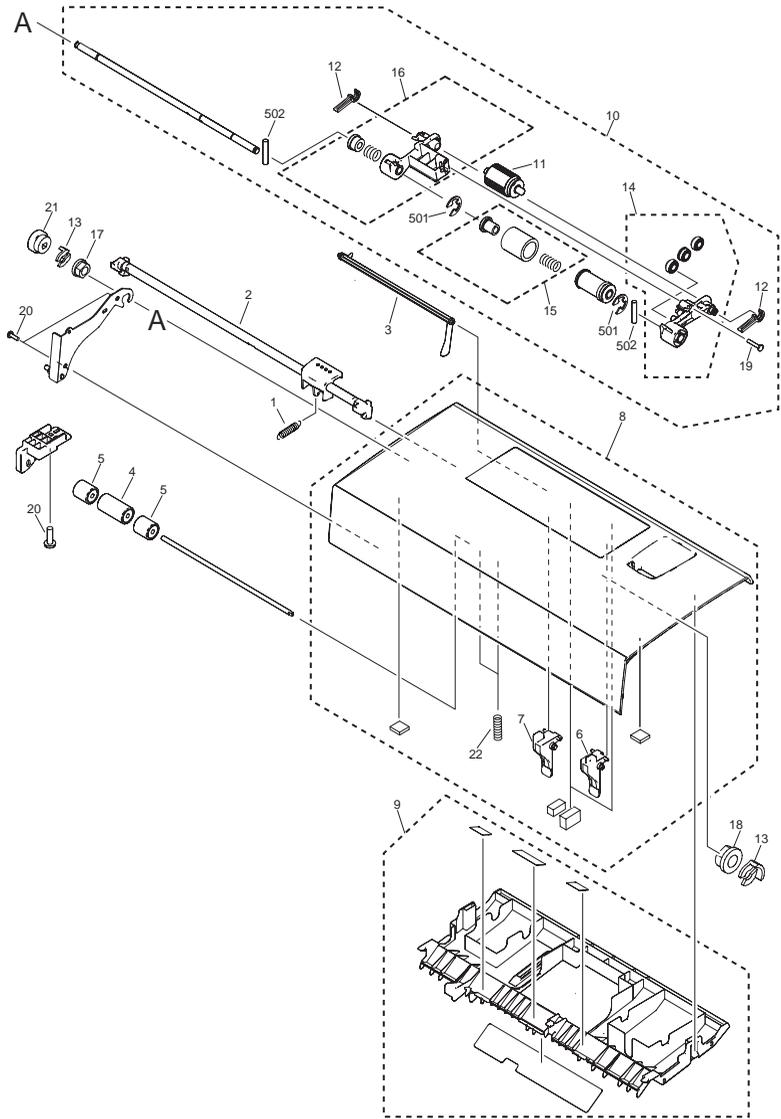

FIGURE & KEY NO.	PARTS NUMBER	R A N K	Q'TY	DESCRIPTION	SERIAL NUMBER/ REMARKS	S V C
Fig.P31	FG3-4037-000		1	OPEN/CLOSE PANEL ASSEMBLY	A INCH SIZE/A SIZE	
1	FS4-2754-000		1	SPRING, TENSION		
2	FC3-1477-000		1	LEVER, OPEN/CLOSE		
3	FC3-1478-000		1	LEVER, SENSOR		
4	FC3-1479-000		1	ROLLER, REGISTRATION, 1		
5	FC3-1480-000		2	ROLLER, REGISTRATION, 2		
6	FC3-1540-000		1	SHUTTER, FRONT		
7	FC3-1541-000		1	SHUTTER, REAR		
8	FF3-4629-000		1	PANEL, OPEN/CLOSE	A SIZE	
8	FF3-4629-000		1	PANEL, OPEN/CLOSE		
9	FF3-4630-000		1	GUIDE, OPEN/CLOSE		
10	FG3-4043-000		1	PICK-UP ROLLER ASSEMBLY		
11	FC3-1525-000		1	ROLLER, PICK-UP		
12	FC3-1542-000		2	STOPPER		
13	FC3-1549-000		2	CLIP		
14	FG3-4041-000		1	PICK-UP ARM UNIT, FRONT		
15	FG3-4044-000		1	SEPARATION ROLLER UNIT		
16	FG3-4045-000		1	PICK-UP ARM UNIT,REAR		
17	FS2-1708-000		1	BUSHING		
18	FS2-1710-000		1	BUSHING		
19	FS2-9573-000		1	SCREW, M3X16		
20	FS2-9569-000		4	SCREW, M3X10		
21	FS4-0654-000		1	GEAR, 25T		
22	FS4-2747-000		2	SPRING, COMPRESSION		
501	XD2-1100-502		1			
502	XD3-2200-102		2	PIN, PARALLEL		

FIGURE P33 PAPER FEEDER ASSEMBLY

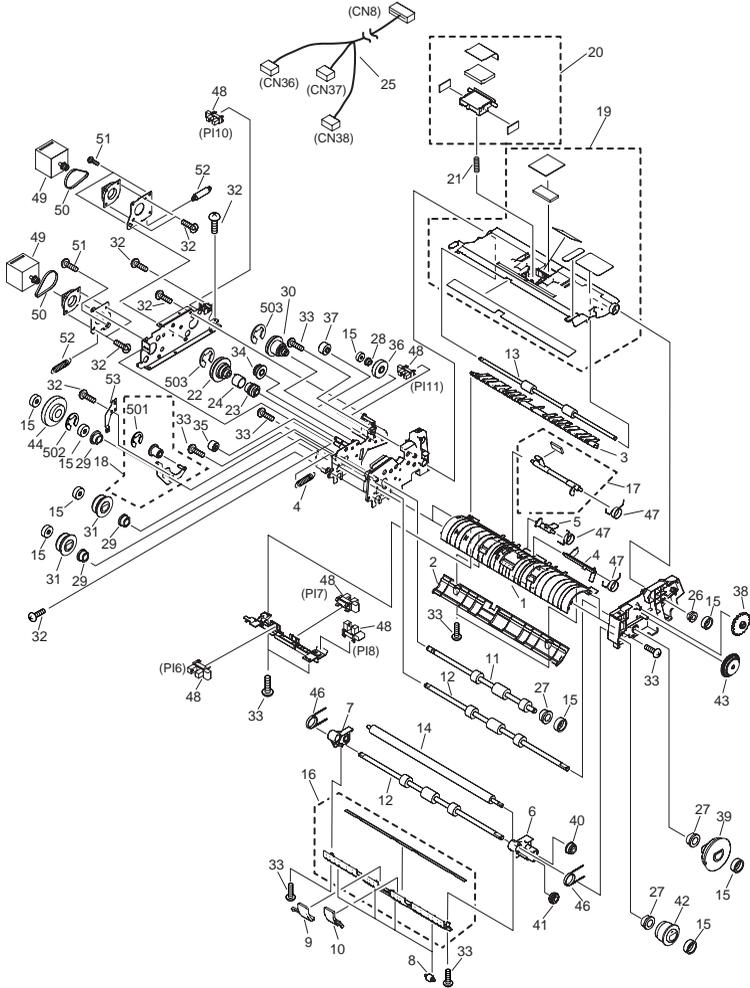

FIGURE & KEY NO.	PARTS NUMBER	R A N K	Q'TY	DESCRIPTION	SERIAL NUMBER/ REMARKS	S V C
Fig.P33	FG3-4038-000		1	PAPER FEEDER ASSEMBLY		
1	FC3-1460-000		1	GUIDE, FEEDER		
2	FC3-1462-000		1	GUIDE, PLATEN		
3	FC3-1463-000		1	FLAPPER		
4	FC3-1465-000		1	FLAG, READ SENSOR		
5	FC3-1466-000		1	FLAG, DELIVERY REVERSE SENSOR		
6	FC3-1469-000		1	ARM, PLATEN, FRONT		
7	FC3-1470-000		1	ARM, PLATEN, REAR		
8	FC3-1471-000		4	ROLLER, PLATEN		
9	FC3-1493-000		1	SPACER, PLATEN, FRONT		
10	FC3-1494-000		1	SPACER, PLATEN, REAR		
11	FC3-1509-000		1	ROLLER, REGISTRATION, 1		
12	FC3-1510-000		2	ROLLER, READ		
13	FC3-1511-000		1	ROLLER, DELIVERY REVERSE		
14	FC3-1512-000		1	ROLLER, WHITE		
15	FC3-1549-000		9	CLIP		
16	FF3-4633-000		1	PLATEN GUIDE UNIT		
17	FF3-4636-000		1	REGISTRATION SENSOR UNIT		
18	FG3-4040-000		1	TENSION ROLLER UNIT		
19	FF3-4631-000		1	REVERSE GUIDE UNIT		
20	FF3-4632-000		1	SEPARATION PAD UNIT		
21	FS4-2746-000		1	SPRING, COMPRESSION		
22	FS2-3885-000		1	PULLEY, 57T,GEAR, 23T		
23	FS4-0645-000		1	GEAR, 16T		
24	FS4-2752-000		11	SPRING, TENSION		
25	FH2-7209-000		1	CABLE, FEEDER SENSOR	CN8,36,37,38	
26	FS2-1708-000		1	BUSHING		
27	FS2-1709-000		3	BUSHING		
28	FS2-1710-000		1	BUSHING		
29	FS2-1711-000		3	BUSHING		
30	FS2-3886-000		1	PULLEY, 57T/19T, GEAR, 23T		
31	FS2-3887-000		2	PULLEY, 27T		

FIGURE & KEY NO.	PARTS NUMBER	RANK	Q'TY	DESCRIPTION	SERIAL NUMBER/REMARKS	SVC
32	FS2-9567-000		9	SCREW,M3X6		
33	FS2-9569-000		12	SCREW, M3X10		
34	FS4-0644-000		1	GEAR, 16T		
35	FS4-0646-000		1	GEAR, 19T		
36	FS4-0647-000		1	GEAR, 25T		
37	FS4-0648-000		1	GEAR, 23T		
38	FS4-0649-000		1	DIAL		
39	FS4-0650-000		1	GEAR, 31T		
40	FS4-0651-000		1	GEAR, 14T		
41	FS4-0652-000		1	GEAR, 15T		
42	FS4-0653-000		1	GEAR, 18T		
43	FS4-0659-000		1	GEAR, 54T/39T		
44	FS4-0660-000		1	GEAR, 33T		
45	FS4-2744-000		1	SPRING, TENSION		
46	FS4-2745-000		2	SPRING, TORSION		
47	FS4-2753-000		3	SPRING, TORSION		
48	WG8-5696-000		5	PHOTO INTERRUPTER, TLP1243	PI6,7,8,10,11	
49	FH5-1142-000		2	MOTOR, STEPPING		
50	XF2-1607-240		2	BELT, TIMING		
51	FS2-9570-000		4	SCREW, M4X7		
52	FS4-2749-000		2	SPRING, TENSION		
53	FC3-1568-000		1	PLATE, GROUNDING		
501	XD2-1100-322		1			
502	XD2-1100-642		1	RING, E		
503	XD2-1100-502		1			

Prepared by
OIP HFE Promotion Center
CANON INC.

Canon